

# MICROBORE STRAIGHT SHANK GEAR ADJUST BORING BARS

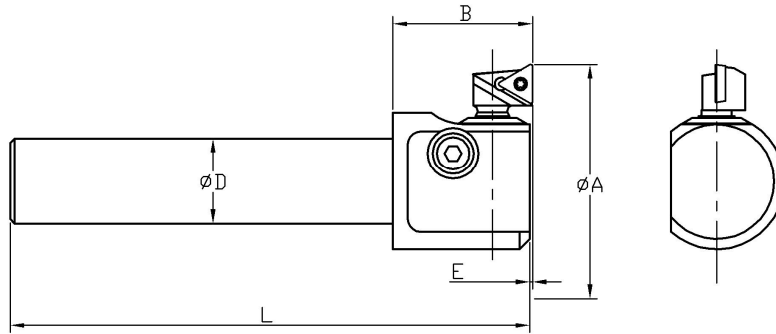

GA Boring Bar Details								
Boring Range		B Head Length	E Min	D Shank Ø	L Length	Cartridge Unit	Insert	Microbore Bar Part No.
Min	Max							
23.0	27.5	-	0.5	20.0	180.0	M022BS095T06-50GA	TC_06T1_	MSS20-23GA-180
27.0	36.0	-	0.5	25.0	180.0	M022-0L095T06-50GA	TC_06T1_	MSS25-27GA-180
36.0	46.0	40.0	0.5	25.0	180.0	M032-0L095T06-50GA	TC_06T1_	MSS25-36GA-180
46.0	53.5	50.0	0.5	32.0	210.0	M052BS095TC-50GA	TC_1102_	MSS32-46GA-210
53.0	67.0	50.0	0.5	32.0	210.0	M052-1L095TC-50GA	TC_1102_	MSS32-53GA-210
67.0	93.0	60.0	0.5	40.0	210.0	M052-0L095TC-50GA	TC_1102_	MSS40-67GA-210
93.0	134.5	60.0	0.5	40.0	230.0	M072-0L095TC-100GA	TC_1102_	MSS40-93GA-230

STANDARD MICROBORE GEAR ADJUST ACCESSORIES				
	Sold only as a set. Please quote Order No.			
IDENTIFY REQUIRED SPARES FROM THE UNIT SIZE				
UNIT SIZE	WORM	SPACER	SNAP RING	G.A. WRENCH
M022	NR2821 SPARES SET			2842
M032	NR3821 SPARES SET			
M052	NR5821 SPARES SET			5842
M072	NR7821 SPARES SET			

MICROBORE STRONGLY ADVISE THAT ANY RECONDITIONING WORK ON GEAR ADJUST BORING BARS OR BORING RINGS IS CARRIED OUT BY FACTORY TRAINED TECHNICIANS.