

# MICROBORE RGA GEAR ADJUST BORING RINGS

Supplied with thro' coolant hole.

For use on standard ADE3282 adaptors

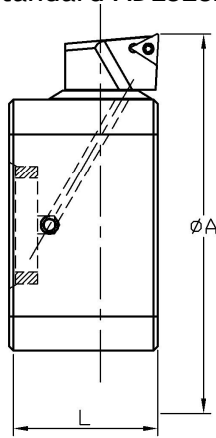

FIGURE 1  
TRIANGULAR INDEXABLE

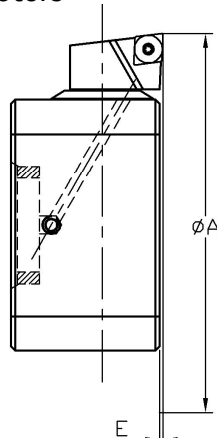
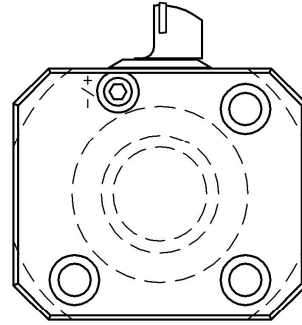





FIGURE 2  
RHOMBOIDAL INDEXABLE



Boring Ring Details							
Boring Range		E Min	L Length	Cartridge Unit	Insert Type		Microbore Ring Part No.
Min	Max				Fig.	Insert.	
169.0	211.0	1.0	50.0	M072-0L095TC-100GA	1	TC_ _1102_ _	RGA169-50-ADE3282
				M072-0L095C09-100GA	2	CC_ _09T3_ _	
210.0	252.0	1.0	50.0	M072-0L095TC-100GA	1	TC_ _1102_ _	RGA210-50-ADE3282
				M072-0L095C09-100GA	2	CC_ _09T3_ _	
251.0	293.0	1.0	50.0	M072-0L095TC-100GA	1	TC_ _1102_ _	RGA251-50-ADE3282
				M072-0L095C09-100GA	2	CC_ _09T3_ _	
292.0	334.0	1.0	50.0	M072-0L095TC-100GA	1	TC_ _1102_ _	RGA292-50-ADE3282
				M072-0L095C09-100GA	2	CC_ _09T3_ _	
333.0	375.0	1.0	50.0	M072-0L095TC-100GA	1	TC_ _1102_ _	RGA333-50-ADE3282
				M072-0L095C09-100GA	2	CC_ _09T3_ _	
374.0	416.0	1.0	50.0	M072-0L095TC-100GA	1	TC_ _1102_ _	RGA374-50-ADE3282
				M072-0L095C09-100GA	2	CC_ _09T3_ _	
415.0	475.0	1.0	50.0	M072-0L095TC-100GA	1	TC_ _1102_ _	RGA415-50-ADE3282
				M072-0L095C09-100GA	2	CC_ _09T3_ _	

STANDARD MICROBORE GEAR ADJUST ACCESSORIES				
	Sold only as a set. Please quote Order No.			
IDENTIFY REQUIRED SPARES FROM THE UNIT SIZE				
UNIT SIZE	WORM	SPACER	SNAP RING	G.A. WRENCH
M072	NR7821 SPARES SET			5842

REFER TO MICROBORE ADAPTOR RANGE CATALOGUE FOR ADE3282 ADAPTOR DETAILS.  
MICROBORE STRONGLY ADVISE THAT ANY RECONDITIONING WORK ON GEAR ADJUST BORING BARS OR BORING RINGS IS CARRIED OUT BY FACTORY TRAINED TECHNICIANS.