

# MICROBORE RGA GEAR ADJUST BORING RINGS

Supplied with thro' coolant  
For use on standard ADE2248 adaptors

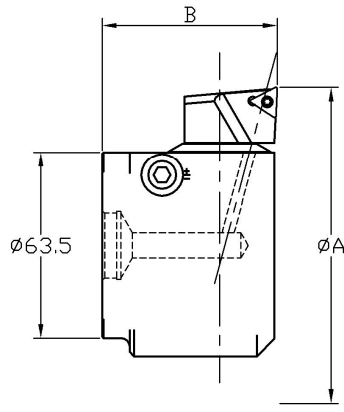

FIGURE 1  
TRIANGULAR INDEXABLE

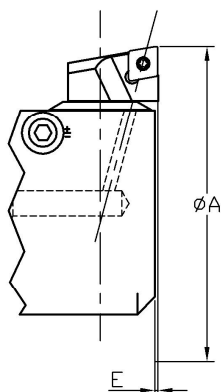
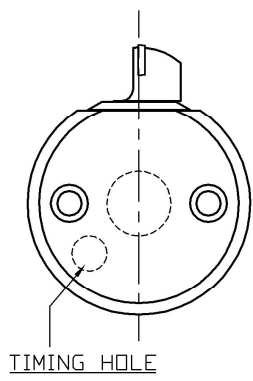



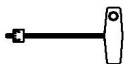

FIGURE 2  
RHOMBOIDAL INDEXABLE



Boring Ring Details							
Boring Range		E Min	L Length	Cartridge Unit	Insert Type		Microbore Ring Part No.
A					Fig.	Insert.	
Min	Max						
93.0	135.0	1.0	60.0	M072-0L095TC-100GA	1	TC_1102_	RGA093-60-ADE2248
				M072-0L095C09-100GA	2	CC_09T3_	
131.0	173.0	1.0	60.0	M072-0L095TC-100GA	1	TC_1102_	RGA131-60-ADE2248
				M072-0L095C09-100GA	2	CC_09T3_	
169.0	211.0	1.0	60.0	M072-0L095TC-100GA	1	TC_1102_	RGA169-60-ADE2248
				M072-0L095C09-100GA	2	CC_09T3_	

STANDARD MICROBORE GEAR ADJUST ACCESSORIES				
	Sold only as a set. Please quote Order No.			
IDENTIFY REQUIRED SPARES FROM THE UNIT SIZE				
UNIT SIZE	WORM	SPACER	SNAP RING	G.A. WRENCH
M072	NR7821 SPARES SET			5842

REFER TO MICROBORE ADAPTOR RANGE CATALOGUE FOR ADE2248 ADAPTOR DETAILS.

MICROBORE STRONGLY ADVISE THAT ANY RECONDITIONING WORK ON GEAR ADJUST BORING BARS OR BORING RINGS IS CARRIED OUT BY FACTORY TRAINED TECHNICIANS.