

TWO-TOOL PARALLEL SHANK BORING BARS

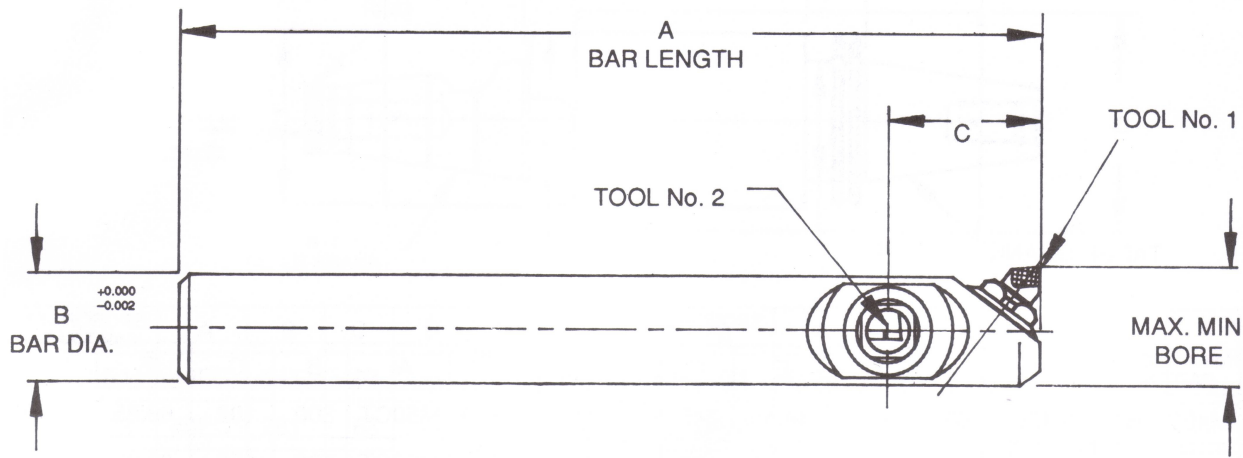

MICROBORE PART NO.	A BAR LENGTH	B BAR DIA.	C	TOOL NO	BORING RANGE		UNIT	BORING RANGE		UNIT	DIAL GRADS
					MIN	MAX		MIN	MAX		
04PAR	7	1/2	-	1	17/32	5/8	M1B2	-	-	-	40
045PAR	7	9/16	-	1	19/32	27/32	M1A2	-	-	-	40
05PAR	8	5/8	7/8	1	3/4	29/32	M2B2	15/16	1 3/32	M2B3	40
				2	1	1 3/16	M2B5	1 1/8	1 5/16	M2B6	50
06PAR	8	3/4	1 1/8	1	29/32	1 1/8	M3B2	1 3/32	1 5/16	M3B3	40
				2	1 1/8	1 9/16	M2A5	1 1/4	1 11/16	M2A5	50
07PAR	8	7/8	1 1/8	1	1 1/8	1 9/16	M3A2	1 5/16	1 13/16	M3A3	40
				2	1 7/16	2 1/16	M3A5	1 5/8	2 1/4	M3A6	50
08PAR	8 1/2	1	1 1/2	1	1 3/16	1 11/16	M3A2	1 3/8	1 7/8	M3A3	40
				2	1 9/16	2 3/16	M3A5	1 3/4	2 3/8	M3A6	50
09PAR	10	1 1/8	1 1/2	1	1 1/2	1 13/15	M5B2	1 27/32	2 5/32	M5B3	40
				2	1 3/4	2 3/8	M3A5	1 15/16	2 9/16	M3A6	50
12PAR	10 1/2	1 1/2	1 15/16	1	1 3/4	2 1/2	M5A2	2 3/32	2 27/32	M5A3	40
				2	2 5/16	3 1/4	M5A5	2 9/16	3 1/2	M5A6	50
17PAR	19	2 1/8	2 1/4	1	2 7/16	3 5/16	M7A2	2 25/32	3 21/32	M7A3	80
				2	3 3/16 4	4 5/16 5 1/8	M7A5 M7A6	4 1/2	5 5/8	M7A7	100
20PAR	19	2 1/2	2 1/2	1	3 1/4	4 1/8	M7A2	3 19/32	4 15/32	M7A3	80
				2	3 7/8 4 11/16	5 5 13/16	M7A5 M7A6	5 3/16	6 5/16	M7A7	100
26PAR	26	3 1/4	3 1/4	1	4 1/16	5 13/16	M10A2	4 3/4	6 1/2	M10A3	80
				2	4 15/16 5 9/16	7 3/16 7 13/16	M10A5 M10A6	6 5/16	8 9/16	M10A7	100

(Measurements in inches)