

Microbore ISO 80° rhomboid indexable units

Imperial

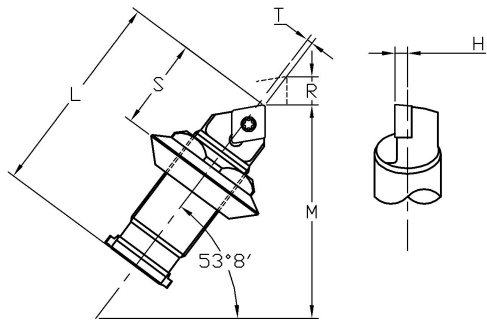

Left Hand Available. Prefix order code with LH



Microbore Unit	Insert	Dimensions in Inches					
		L	M	R	S	T	H
3A2C06-40	CC__0602__	1.00	1.03	0.25	0.43	0.010	0.620
3B2C06-40		0.84	0.91	0.13	0.43	0.010	0.620

5A2C06-40	CC__0602__	1.56	1.62	0.41	0.63	0.047	0.094
5B2C06-40		1.31	1.41	0.22	0.63	0.047	0.094

7A2C09-80	CC__09T3__	2.19	2.31	0.50	1.00	0.063	0.125
7B2C09-80		1.94	2.09	0.31	1.00	0.063	0.125

10A2C12-80	CC__1204__	3.00	3.09	0.87	1.25	0.031	0.187
10B2C12-80		2.50	2.69	0.50	1.25	0.031	0.187

Left Hand Available. Prefix order code with LH

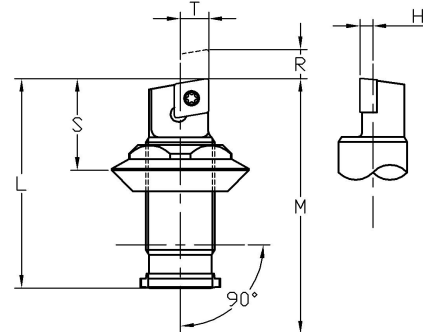

Microbore Unit	Insert	Dimensions in Inches					
		L	M	R	S	T	H
3A5C06-50	CC__0602__	1.0	1.22	0.31	0.43	0.156	0.620
3B5C06-50		0.84	1.06	0.16	0.43	0.156	0.620

5A5C06-50	CC__0602__	1.56	1.91	0.53	0.63	0.218	0.094
5B5C06-50		1.31	1.66	0.25	0.63	0.218	0.094

7A5C09-100	CC__09T3__	2.19	2.63	0.66	1.00	0.250	0.125
7B5C09-100		1.94	2.38	0.41	1.00	0.250	0.125

10A5C12-100	CC__1204__	3.00	3.50	1.13	1.25	0.375	0.187
10B5C12-100		2.50	3.00	0.63	1.25	0.375	0.187

SPARES LIST

Angular Mounted Unit Spares	Microbore Unit	Dial	Lockscrew		Washer	Top Adjust Spring	Insert Key	Insert Screw	Dial Wrench	Hex Key
		Angular Grads	A Length	B Length						
		3A2C06-40	3704	S113						
3B2C06-40		S112								
5A2C06-40	5704	S121								
5B2C06-40			S120							
7A2C09-80	7708	S132								
7B2C09-80			S131							
10A2C12-80	10708	S144								
10B2C12-80			S143							

Square Mounted Unit Spares	Microbore Unit	Dial	Lockscrew		Washer	Top Adjust Spring	Insert Key	Insert Screw	Dial Wrench	Hex Key
		Square Grads	A Length	B Length						
		3A5C06-50	3705	S113						
3B5C06-50		S112								
5A5C06-50	5705	S121								
5B5C06-50			S120							
7A5C09-100	7710	S132								
7B5C09-100			S131							
10A5C12-100	10710	S144								
10B5C12-100			S143							

All dimensions shown are measured over a qualified O4 insert radius. All cartridges are supplied with insert screw. Inserts to be ordered separately.

Alternative style units and lead angles can be supplied to order. Please enquire for delivery time.