

MICROBORE MODULAR GEAR ADJUST BORING BARS

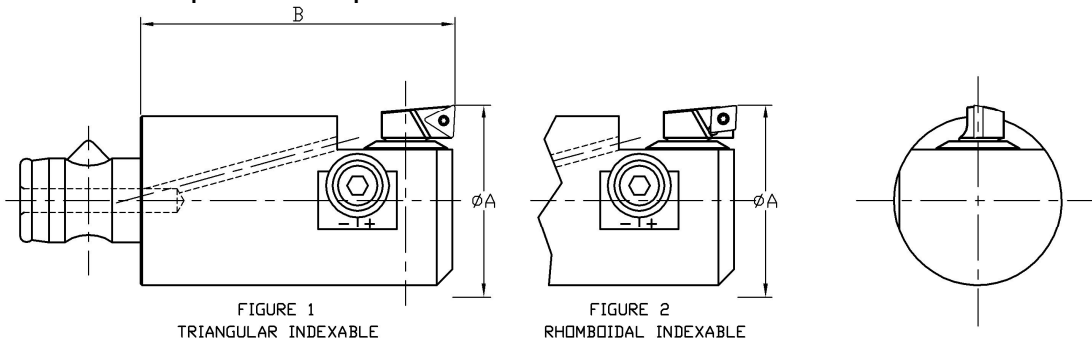

Supplied with thro' coolant hole.
For use on ABS® compatible adaptors



Boring Bar Details							
Boring Range		B Min	ABS Coupling	Cartridge Unit	Insert Type		Microbore Part Number
Min	Max				Fig.	Insert	
23.0	27.5	60	25	M022BS095T06-50GA	1	TC__06T1__	GA-23A-60-ABS25
27.0	36.0	60	25	M022-0L095T06-50GA	1	TC__06T1__	GA-27A-60-ABS25
				M022-0L095C06-50GA	2	CC__0602__	
36.0	46.0	60	32	M032-0L095T06-50GA	1	TC__06T1__	GA-36A-60-ABS32
				M032-0L095C06-50GA	2	CC__0602__	
46.0	53.5	60	40	M052BS095TC-50GA	1	TC__1102__	GA-46A-60-ABS40
				M052BS095C06-50GA	2	CC__0602__	
53.0	67.0	160	40	M052-1L095TC-50GA	1	TC__1102__	GA-53A-60-ABS40
				M052-1L095C06-50GA	2	CC__0602__	
67.0	93.0	60	50	M052-0L095TC-50GA	1	TC__1102__	GA-67A-60-ABS50
				M052-0L095C06-50GA	2	CC__0602__	
93.0	134.5	60	63	M072-0L095T06-100GA	1	TC__1102__	GA-93A-60-ABS63
				M072-0L095C09-100GA	2	CC__09T3__	

STANDARD MICROBORE GEAR ADJUST ACCESSORIES				
	Sold only as a set.			
IDENTIFY REQUIRED SPARES FROM THE UNIT SIZE				
UNIT SIZE	WORM	SPACER	SNAP RING	G.A. WRENCH
M022	NR2821 SPARES SET			2842
M032	NR3821 SPARES SET			
M052	NR5821 SPARES SET			5842
M072	NR7821 SPARES SET			

REFER TO ADAPTOR RANGE CATALOGUE FOR COMPATIBLE MODULAR ADAPTORS.

MICROBORE STRONGLY ADVISE THAT ANY RECONDITIONING WORK ON GEAR ADJUST BORING BARS OR BORING RINGS IS CARRIED OUT BY FACTORY TRAINED TECHNICIANS.

